



US00D477797S

(12) **United States Design Patent** (10) **Patent No.:** **US D477,797 S**  
**McCoy et al.** (45) **Date of Patent:** **\*\* Jul. 29, 2003**

(54) **SINGLE-WHEEL TRAILER**  
(75) Inventors: **Richard W. McCoy**, Granger, IN (US);  
**Katherine A. Adams**, Mishawaka, IN (US);  
**John J. Kass**, Granger, IN (US);  
**Jason R. Moldthan**, Osceola, IN (US)  
(73) Assignee: **Cequent Towing Products, Inc.**,  
Plymouth, MI (US)  
(\*\*) Term: **14 Years**  
(21) Appl. No.: **29/166,876**  
(22) Filed: **Sep. 5, 2002**  
(51) **LOC (7) Cl.** ..... **12-10**  
(52) **U.S. Cl.** ..... **D12/101**  
(58) **Field of Search** ..... D12/101; 280/63,  
280/78, 789, 650, 414.5, 204, 492, 494

4,426,097 A 1/1984 Livingston  
4,437,676 A 3/1984 Kittrell  
D281,312 S \* 11/1985 Russell ..... D12/101  
4,567,844 A \* 2/1986 Johnson ..... D12/101 X  
4,744,582 A 5/1988 Wykhuis et al.  
4,756,541 A 7/1988 Albitre  
5,011,170 A 4/1991 Forbes et al.  
5,067,738 A 11/1991 O'Connor  
5,098,113 A 3/1992 Albitre  
5,240,266 A 8/1993 Kelley et al.  
5,368,325 A 11/1994 Hazen  
5,641,173 A 6/1997 Cobb, Jr.  
5,791,670 A 8/1998 Hunker  
5,984,342 A 11/1999 Ysker  
6,042,138 A \* 3/2000 Shreck ..... 280/492  
6,182,990 B1 2/2001 Everett  
6,349,955 B1 2/2002 Cottard et al.  
6,470,981 B1 \* 10/2002 Sueshige et al. .... 280/786  
2001/0026055 A1 10/2001 Havener  
2001/0038190 A1 11/2001 Provencher

\* cited by examiner

*Primary Examiner*—Melody N. Brown  
(74) *Attorney, Agent, or Firm*—King & Schickli, PLLC

(56) **References Cited**

**U.S. PATENT DOCUMENTS**

1,401,786 A	12/1921	Kapferer
1,794,630 A	3/1931	Linn
1,880,703 A	10/1932	Bischoff et al.
1,968,046 A	7/1934	Linn
2,009,548 A	7/1935	Goin et al.
2,027,127 A	1/1936	Tastenhoye
2,033,298 A	3/1936	Pribil
RE20,292 E	3/1937	Brown
2,157,186 A	5/1939	Pinter, Sr. et al.
2,494,421 A	1/1950	Wittke
2,564,996 A	8/1951	Rasbach
2,826,425 A	3/1958	Hoepfer
2,834,632 A	5/1958	Mattox
3,263,383 A	8/1966	Foster
3,877,714 A	4/1975	Black
3,917,316 A	11/1975	Furnish
3,944,259 A	3/1976	Miller
4,266,793 A	5/1981	Pryor
D260,011 S	7/1981	Williams
4,372,569 A	2/1983	Otterson
4,403,802 A	9/1983	Jones

(57) **CLAIM**

The ornamental design of a single-wheel trailer, as shown and described.

**DESCRIPTION**

FIG. 1 is a perspective view of the single-wheel trailer of the present invention;  
FIG. 2 is a top plan view thereof;  
FIG. 3 is a bottom plan view thereof;  
FIG. 4 is a left side elevational view thereof;  
FIG. 5 is a right side elevational view thereof;  
FIG. 6 is a front elevational view thereof; and,  
FIG. 7 is a rear elevational view thereof.  
The wheel shown in broken lines throughout the drawing views is for illustrative purposes only and forms no part of the claimed design.

**1 Claim, 4 Drawing Sheets**

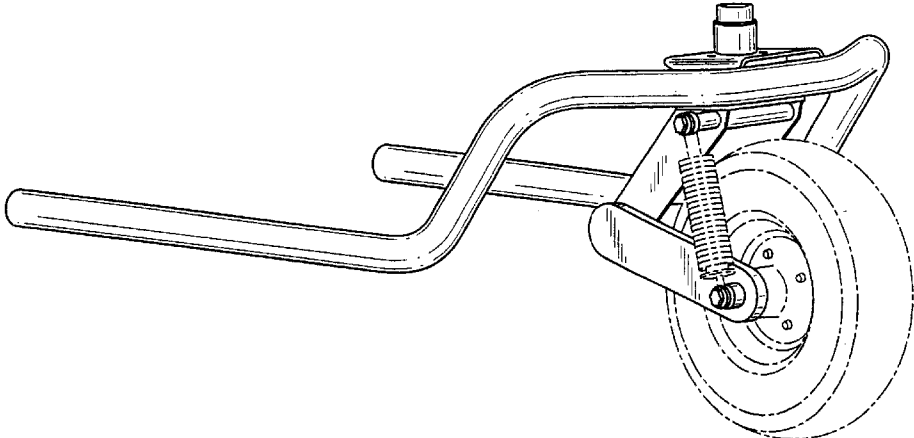

FIG. 1

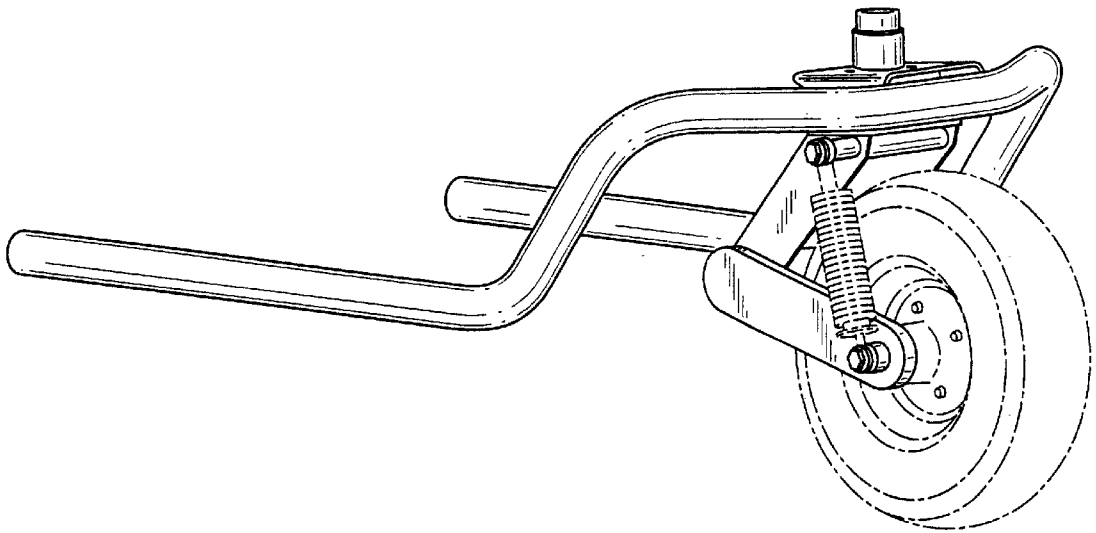

FIG. 2

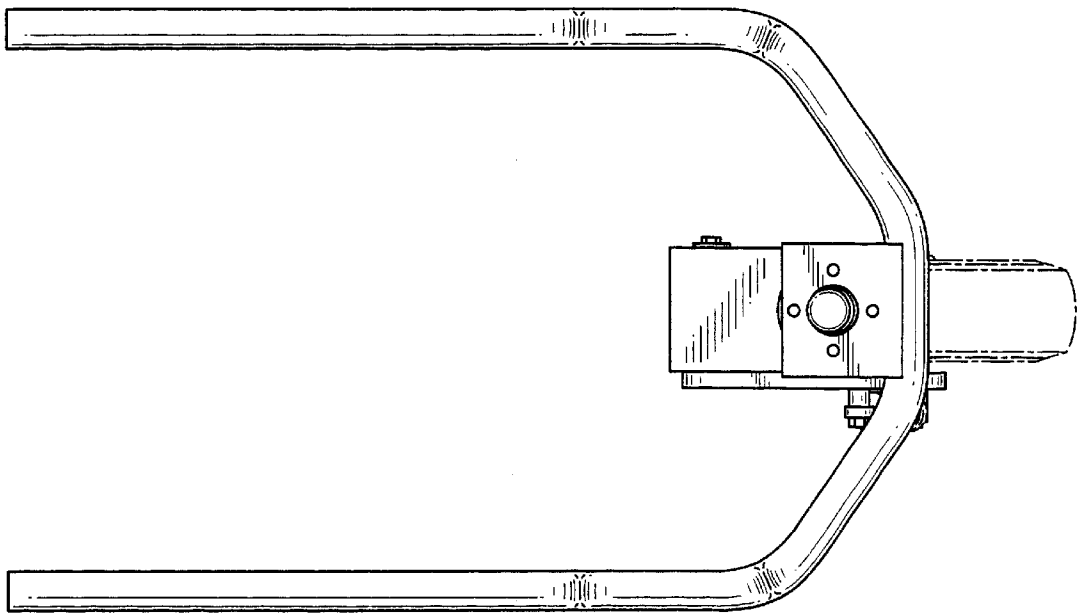

FIG. 3

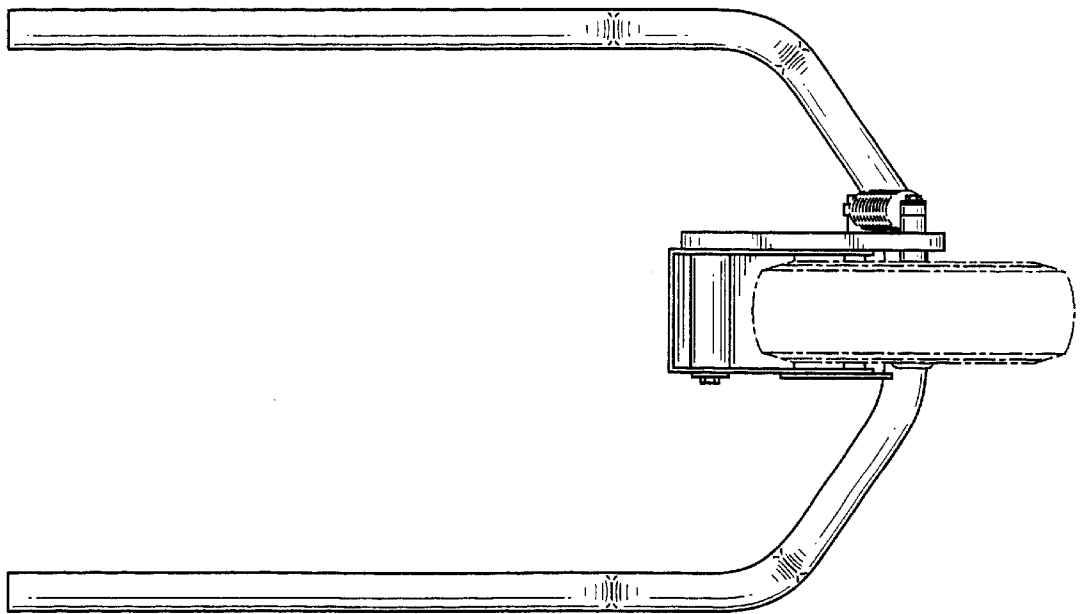

FIG. 4

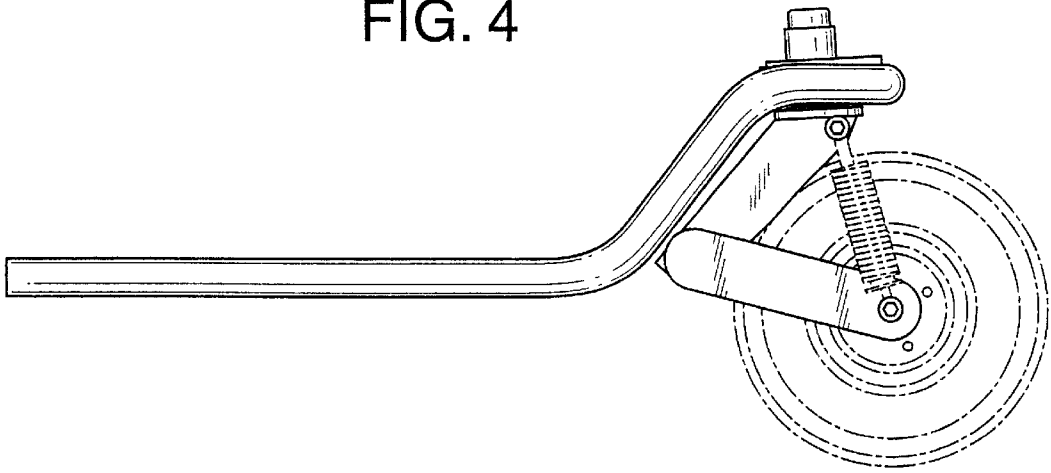

FIG. 5

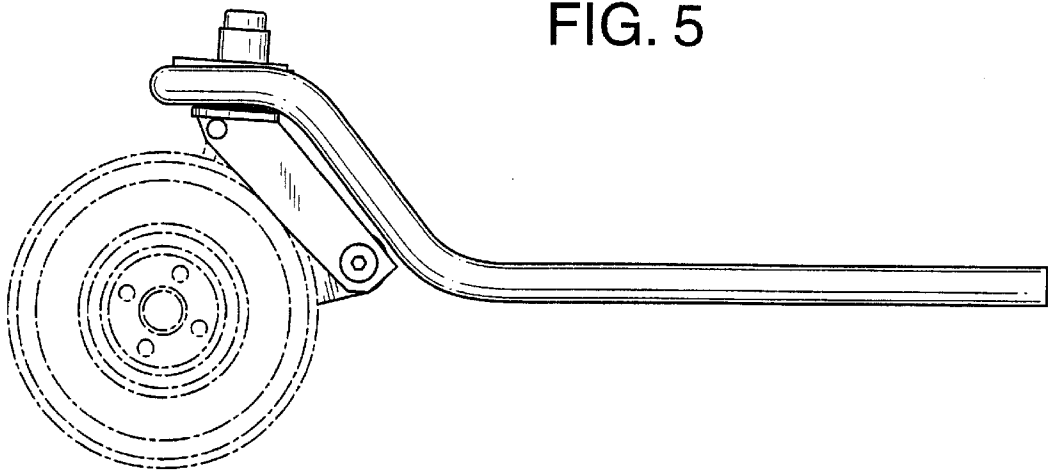

FIG. 6

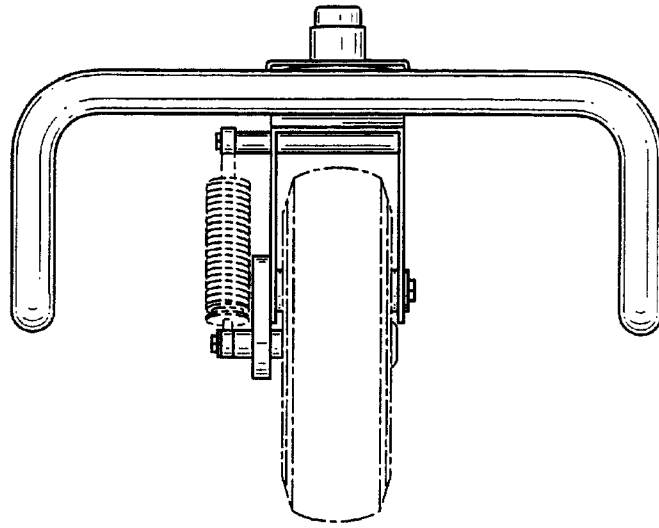

FIG. 7

